

National Law University Delhi

Sector-14, Dwarka, New Delhi – 110078

N.I.T. No.:01/2024-25

Name of Work: Supply of Gym Equipment at Sector-14, Dwarka, New Delhi

Estimated Cost : Rs. 9,50,000.00 Approximately
Earnest Money : Rs. 20,000.00
Time Period : 10 Days

This N.I.T. is approved for Rs. 9,50,000.00 (Rupees Nine Lakh fifty thousand Only) By The Registrar, National Law University, Delhi

INDEX

S.No.	Contents	Page No.
1	Notice Inviting Quotations	1-2
2	Check list for bidders	3-4
3	List of documents to be attached with the bid submission in a separate envelope	5
4	Item Rates Quotation	6
5	Acceptance	7
7	General Conditions and Specifications	8
8	Bill of Quantity (BOQ)	9-13
9	Checklist	14

Certified that this N.I.T contains page 1 to 14

NOTICE INVITING QUOTATIONS

The Registrar, National Law University Delhi invites Quotations from the eligible agencies, who satisfy the criteria for Supply of Gym Equipment as per requirement. The agency should have past experience in the similar nature of works as per the below details.

- A. 3 similar work each of value not less than 40%.
or
B. 2 similar work each of value not less than 60%.
or
C. 1 similar works each of value not less than 80%.

Sr. No	N.I.T No.	Name of item & Location	Estimated Cost put to Quotation	Earn est Money	Period of Completion	Start Date of Receiving Tender	Last date and time of submission of Quotation	Last date and time of Opening of Quotation
1	01	Supply of Gym Equipment at NLU Delhi, Sec -14, Dwarka, New Delhi	Rs9,50,000.00 Appx.	Rs. 20,000.00	10 Days	15.07.2024	05.08.2024 1:00 pm	05.08.2024 2:00 pm

Interested bidders may download the quotation from the University website i.e. www.nludelhi.ac.in and Delhi govt. e-procurement website www.delhigovtprocurement.com on free of cost.

The Quotation Box is available at the main reception of the University, where Quotations are to be submitted.

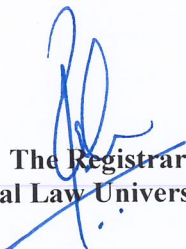
The Registrar
National Law University, Delhi

CHECK LIST FOR BIDDERS FOR SUBMISSION OF BIDS

1. The bidder should read all the instructions, items & conditions, contract clauses, nomenclature of items, specifications etc., contained in the bid document very carefully, before quoting the rates.
2. Rates must be filled both in words and figures. Amount should be worked out for all the items.
3. The bidder shall quote his rebate if required, mentioning specifically on what component it is applicable otherwise it shall be considered general rebate on total quoted rates.

Similar work means “Supply of Gym Equipment”.

1. The time allowed for carrying out the work will be 10 Days from the date of work order.
2. Earnest money in the form of Demand Draft (drawn in favour of “The Registrar, National Law University Delhi”) must be deposited in the University in a separate envelope.

Bid/Tender documents submitted by intending bidders shall be opened only of those bidders, **who has deposited EMD** and other documents submitted, are found in order.

3. The bid submitted shall become invalid if:

1. The bidder is found ineligible.
2. The bidder does not deposit original EMD.
3. The bidder does not enclose all the documents (including GST registration and copy of Pan Card) as stipulated in the bid documents.
4. If any discrepancy is noticed in the submitted documents by the lowest bidder.
5. If a tenderer quotes nil rates against each item in item rate quotation or does not quote any percentage above/ below on the total amount of the quotation or any section/ sub head in percentage rate quotation, the quotation shall be treated as invalid and will not be considered as lowest tenderer.
6. The Registrar NLUD does not bind itself to accept the lowest or any other quotation and reserves to itself the authority to reject any or all the quotations received without the assignment of any reason. All quotations in which any of the prescribed condition is not fulfilled or any condition including that of conditional rebate is put forth by the tenderer shall be summarily rejected.
7. The competent authority reserves the right of accepting the whole or any part of the quotation and the tenderer shall be bound to perform the same at the rate quoted.
8. The bid for the works shall remain open for acceptance for a period of **10 Days (10)** from the date of opening of bids. If any tenderer withdraws his quotation before the said period or issue of letter of acceptance, whichever is earlier, or makes any modifications in the terms and conditions quotation which are not acceptable to the department, then the NLUD shall, without prejudice to any other right or remedy, be at liberty to **forfeit 50%** of the said earnest money as aforesaid. Further the tenderer shall not be allowed to participate in the re-tendering the process of the work.

9. This Notice inviting tender shall form a part of the contract document. The successful tenderer/agency, on acceptance of his quotation by the Accepting Authority, shall, within 10 days from the stipulated date of start of the work, sign the contract consisting of:-
- a. The notice inviting tender, all the documents including additional conditions, specifications and drawings, if any, forming part of the quotation as uploaded at the time of invitation of quotation and rates quoted at the time of submission of tender/quotation and acceptance thereof together with any correspondence leading thereto.



The Registrar
National Law University, Delhi

List of Documents to be attached with the bid submission in a separate envelope:

- i. Demand Draft against EMD.
- ii. Certificate of Registration GST and Income Tax PAN CARD.

Note: No cutting/over writing shall be allowed in Demand Draft of any scheduled Bank. If found so, their bid will be rejected.

The Registrar
National Law University, Delhi

National Law University, Delhi
Sector-14 Dwarka, New Delhi – 110078
Item Rate Quotation

Quotation for the work of: - **Supply of Gym Equipment at National Law University Delhi, Sector-14, Dwarka, New Delhi.**

- (i) Quotations are to be submitted in the drop box which is at the reception of the University.
- (ii) To be opened on **05.08.2024 at 02:00 PM in the National Law University, Delhi.**

(UNDERTAKING)

I/We have read and examined the '**Notice Inviting Quotation**'. Specifications General Rules and Directions, Conditions of Contract, clauses of contract, Special conditions, Schedule of Rate & other documents and Rules referred to in the conditions of contract and all other contents in the quotation documents for the work.

I/We hereby quotation for the execution of the work specified for the Registrar of NLU Delhi within the time specified, schedule of quantities and in accordance in all respects with the specifications and instructions laid down in the notice for tender.

We agree to keep the quotation open for **ten (10) days** from the due date of its opening and not to make any modifications in its terms and conditions.

A sum of **20,000.00 is here by forwarded in** the form of demand draft/Banker's Cheque of a Scheduled bank as earnest money. If I/we, fail to furnish the prescribed performance guarantee within prescribed period, I/we agree that the said competent authority's office shall without prejudice to any other right or remedy, be at liberty to forfeit the said earnest money absolutely. Further, if I/we fail to commence work as specified, I/we agree that competent authority's office shall without prejudice to any other right or remedy available in law, be at liberty to forfeit the said performance guarantee absolutely. The said Performance guarantee shall be guarantee to execute all the works referred in the tender documents upon the term and conditions contained.

Further, I/We agree that in case forfeiture of earnest money or performance guarantee as aforesaid, I/We shall be debarred for participation in the re-tendering process of the work.

Dated.....

Signature of Agency

Postal Address

.....
.....

Witness: #

Address: #

Occupation: #

ACCEPTANCE

The above quotation (as modified by you as provided in the letters mentioned hereunder) is accepted by me for and on behalf of the University for a sum of Rs. *.....(Rupees*.....)

The letters referred to below shall form part of this contract Agreement:-

- i) *
- ii)*

iii) For & on behalf of the University.

Signature.....

Designation: **Registrar**

National Law University, Delhi

Dated *.....













To be filled by the agency

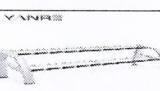



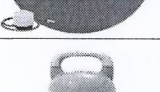
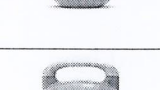

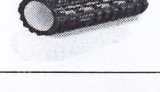
General Terms & Conditions







1. The agency is to submit earnest money of Rs. 20,000/- (Rupees Twenty Thousand Only) in the form of Demand Draft in the name of Registrar, National Law University, Delhi along with the quotation.
2. The successful bidder shall deposit the 5% of Performance Guarantee (P.G.) of the tendered amount and may be released after successful completion of one year.
3. The agency should have minimum three year experience for supply of gym equipment to government organisations/institutions/universities and also attach the copy of work orders of the same.
4. The successful bidder has to supply the equipment(s) / good(s) within ten (10) days from the issuance of the purchase order. Failing which, the order can be cancelled by the establishment i.e. National Law University Delhi.
5. It is mandatory that, the agency/firm/ supplier shall possess registered office & service centre in Delhi NCR in connection with gym equipment's like dumbbell, plates, benches and machines illustrated at annexure-II. The agency/firm/ supplier has to submit the scan copy of proof otherwise bids/tender will treated cancelled.
6. The committee constituted by the competent authority of this establishment will site visit the registered office(s) /showroom(s)/ service of those bidder(s), who have qualified in the technical bid evaluation. The committee will recommend the suitable agency/firm/ supplier (three or above) to be qualified for financial bid.
7. The supplier (s)/ bidder(s) have to supply the gym equipment(s)/ good(s) according as per Annexure-II.
8. All shipping, commissioning and installation fees shall be inclusive.
9. Cutting and overwriting in the quotation are not allowed. If, there is cutting and overwriting such quotation will not be entertained.
10. The agency is required to submit its bids/quotations on their letter head. The University is not bound to accept the lowest bid.
11. Copy of PAN card is to be enclosed.
12. Copy of GST Registration certificates is to be enclosed.
13. Registration certificate as per existing norms (indicating the legal status-company/partnership firm/proprietorship concern etc.) to be enclosed.
14. In case the supplied items are not according to specifications order will be cancelled.
15. The agency/firm/ supplier should be manufacturer/ franchisee/ authorized dealer. In this regard, please attach scan copy of requisite document/ proof.
16. No manpower will be provided by the University for Loading and unloading the goods/material.
17. The bids/tender received after last date and time of submission will not be entertained.
18. The conditional tenders /bids would not be accepted.
19. If it is found, that the supplied items are not satisfactory and as per requirement, the university have rights to cancel the order and no payment will be made.
20. The university has reserved the rights to cancel the quotation/tender without assigning any reason/ notice.
21. Bidder's offer is liable to be rejected if they don't upload and fill the check list (annexure-III) any of the certificates/ documents sought in the Bid document, Additional Terms & Condition, if any
22. Bidder financial standing: The bidder should not be under liquidation, court receivership or similar proceedings should not be bankrupt. Bidder to upload undertaking to this effect with bid.
23. If the agency is registered under MSME or NSIC, then EMD exemption certificate needs to be enclosed.

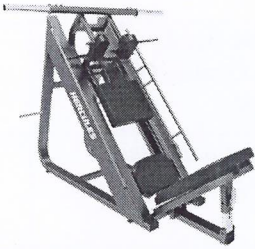
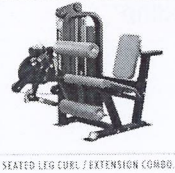



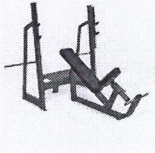

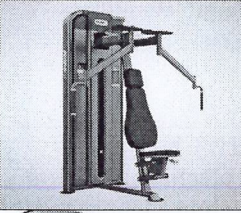

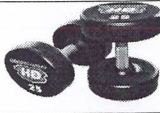

Registrar

BILL OF QUANTITY (BOQ)

S.No	Name of Gym Equipment	Specification	Picture (illustration purpose only)	Qty.	Rate (Rs.)	Amt. (Rs.)
1.	Dumbbell	Rubber fixed weight 1.5 KG		2 pairs		
2.	Dumbbell	Rubber fixed weight 2.5 KG		4 Pairs		
3.	Dumbbell	Rubber fixed weight 5 KG		4 Pairs		
4.	Dumbbell	Rubber fixed weight 7.5 KG		4 Pairs		
5.	Dumbbell	Rubber fixed weight 10 KG		4 Pairs		
6.	Dumbbell Rack	Heavy Duty 20 pair Dumbbell Rack		01 No.		
7.	Resistance Bands	Exercise Bands with Heavy Quality Grip & resistance		02 No.		
8.	Battle Rope	1.25 inch diameter/35 feet length/5 kg weight		01 No.		
9.	Anti-Burst Gym Ball	85 cm (Heavy quality) with foot pump		01 No.		
10.	Competition Kettle bell	5 KG		01 No.		
11.	Competition Kettle bell	10 KG		01 No.		
12.	Foam Rollers	DIA 45X 15 cm (Heavy quality)		01 No.		
13.	Yoga Mats	Thick exercise yoga mat 6 mm (Anti slip)		04 No.		
14.	Imported Olympic Rod With spring lock	7 fit (20 Kg)		02 Nos.		

15.	Imported Straight Rod With spring lock	3 feet		02 Nos.		
16.	Imported Curling Rod With spring lock	3 feet		02 Nos.		
17.	Imported Plates	Bumper fixed weight 2.5 KG		04 Pairs		
18.	Imported Plates	Bumper fixed weight 5 KG		04 Pairs		
19.	Imported Plates	Bumper fixed weight 7.5 KG		04 Pairs		
20.	Imported Plates	Bumper fixed weight 10 KG		04 Pairs		
21.	Imported Plates	Bumper fixed weight 15 KG		04 Pairs		
22.	Leg Press & Hack Squat Machine	LxWxH:208x92x149 cm Heavy duty 2.5 mm thick steel square tube of size 50 mm x 100 mm Seat : High Density PU Weight Material : Cast Iron		01 Nos.		
23.	Leg Curl & Extension	Tube Size - Weight Tower : D75*130*2.5T, Main Frame : PT50*100*2.5T • Product Size (L*W*H): 1385*1336*1617mm • Maximum User weight: 180 Kg • Steel Cable strength: φ5.8, Max Load 1400KGF • Weight Stack: 100 Kg • Seat adjustment mode available • Shroud: High Quality ABS materials	 <small>SEATED LEG CURL / EXTENSION COMBO</small>	01 No.		

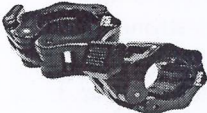
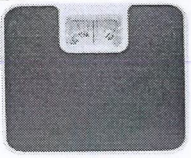
		<ul style="list-style-type: none"> • Pulley: High Quality Nylon material • Guide Rail: Alloy Steel • Weight Plate: Cast Steel • PVC Handle Bar 				
24.	Back & Front pulley machine	Weight stack: 220 lbs.		01 No.		
25.	Decline Bench	Heavy duty 2.5 mm thick steel square tube of size 50 mm x 100 mm. Black powder coated finish with strong double stitched upholstery User weight: 150 Kg. • Cushion: Made of PU		01 No.		
26.	Incline Bench	Heavy duty 2.5 mm thick steel square tube of size 50 mm x 100 mm. Black powder coated finish with strong double stitched upholstery User weight: 150 Kg. • Cushion: Made of PU		01 No.		
27.	Adjustable Bench	Heavy duty 2.5 mm thick steel square tube of size 50 mm x 100 mm. Black powder coated finish with strong double stitched upholstery User weight: 150 Kg. • Cushion: Made of PU		01 No.		
28.	Butterfly Machine	Heavy duty 2.5 mm thick steel tube. Black powder coated finish with strong double stitched upholstery		01 No.		
29.	Chest Press Machine	Heavy duty 2.5 mm thick steel square tube. Black powder coated finish with strong double stitched upholstery User weight: 150 Kg. • Cushion: Made of PU		01 No.		
30.	Imported Plates	Rubber fixed weight 12.5 KG		02 <u>Pairs</u>		

31.	Imported Plates	Rubber fixed weight 20 KG		02 Pairs		
32.	Imported Plates	Rubber fixed weight 25 KG		02 Pairs		
33.	Imported Plates	Rubber fixed weight 30 KG		01 Pair		
34.	Dumbbell	Rubber fixed weight 15 KG		02 Pairs		
35.	Dumbbell	Rubber fixed weight 20 KG		02 Pairs		
36.	Dumbbell	Rubber fixed weight 25 KG		02 Pairs		
37.	Dumbbell	Rubber fixed weight 30 KG		01 Pair		
38.	Dumbbell	Rubber fixed weight 40 KG		01 Pair		
39.	Stretching Band	Medium Resistance 20-35lbs		02 Nos.		
40.	Olympic Barbell Lock clamps	Olympic Bar Collar Plastic Rod Locks, Barbell Clip Pair For 50 Mm Barbells, Plastic Regular Barbell Locks For Olympic Weight Lifting Barbells, Black		02 Pairs		
41.	Weight Machine	ACU-CHECK Analog Weight Machine for Body Weight Manual Capacity 120Kg Weighing Scale Mechanical Weighing Scale		02 Nos.		
42.	Gym Chalk Powder	Gym Chalk Powder for Superior Grip Weightlifting Deadlift		02 KG		
43.	D Bar Handle	D Handle Gym Chrome Steel Cable Cross Solid Steel		01 No.		

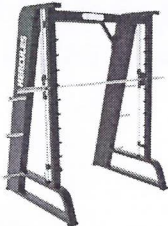
44.	Smith Machine	Heavy Duty 2.5 mm thick stel square tube of size 50 mmx 100 mm.		01 No.		
Total						
GST						
Grand Total						

The Registrar
National Law University, Delhi

CHECKLIST

S.No.	Certificate/ Document required	Document number/ details	Uploaded (Yes or No)
1.	Registered office & service centre in Delhi NCR in connection with gym equipment's like dumbbell, plates, benches and machines illustrated at annexure-II		
2.	Copy of GST Registration certificates		
3.	Copy of PAN card		
4.	Registration certificate as per existing norms (indicating the legal status- company/partnership firm/proprietorship concern etc.)		
5.	Please attach scan copy of requisite document/ proof regarding manufacturer/ franchisee/ authorized dealer.		
6.	If the agency is registered under MSME or NSIC, then EMD exemption certificate needs to be enclosed		
7.	3 similar work each of value not less than 40%. or 2 similar work each of value not less than 60%. or 1 similar works each of value not less than 80%.		
8.	Copy of previous three years work orders		
9.	Scanned copy of EMD of Rs.20,000.00 in the form of Demand Draft		

Date: _____

Place: _____

Name of Authorized person: _____

Sign & Stamp of company: _____